



SOF INTERNATIONAL GENERAL KNOWLEDGE OLYMPIAD

Total Questions : 50

Time : 1 hr

PATTERN & MARKING SCHEME				
Section	(1) General Awareness	(2) Current Affairs	(3) Life Skills	(4) Achievers Section
No. of Questions	30	10	5	5
Marks per Ques.	1	1	1	3



Scan the QR code for more details

SYLLABUS

Plants and Animals, India and the World, Science and Technology, Earth and Its Environment, Universe, Language and Literature, Entertainment, Social Studies, Sports, Quantitative Aptitude and Reasoning, Current Affairs, Life Skills (Empathy, Effective Communication, Critical Thinking, Creative Thinking, Coping with Stress, Decision Making, Problem Solving, Interpersonal Skills, Managing Emotions, Self-awareness).

Achievers Section : Higher Order Thinking Questions from the above given Syllabus.

- Identify the rainforest which is called the 'Lungs of our Planet'.
(A) Asian rainforest
(B) Amazon rainforest
(C) Assam rainforest
(D) African rainforest
- When a bank statement says ₹ 500 credited to your account, it means _____.
(A) ₹ 500 is deposited in your account
(B) ₹ 500 is withdrawn from your account
(C) ₹ 500 is fined on your account
(D) None of these
- Identify the Indian scientist who found out that when light passes through a transparent material, some of it undergoes change in its wavelength.
(A) Homi J. Bhabha
(B) C.V. Raman
(C) C.N.R. Rao
(D) M.S. Swaminathan
- A great amount of work pertaining to Indus Valley Civilisation is being done at village Bhirrana. Where is this village located?
(A) Gujarat
(B) Haryana
(C) Tamil Nadu
(D) Bihar
- Mangalyaan has been called "The Super Smart Spacecraft". Which organisation is involved in it?
(A) NASA
(B) ISRO
(C) JAXA
(D) ESA
- If one has lactose intolerance, he /she is likely to avoid _____.
(A) Sugar
(B) Milk
(C) Honey
(D) Alcohol
- Who is the current President of Indonesia?
(A) Shinzo Abe
(B) Joko Widodo
(C) Xi Jinping
(D) None of these
- If in the class while the teacher is teaching a lesson, then _____.
(A) It is a good idea to read the same chapter
(B) It is a good practice to take notes
(C) It matters little as one can catch up in coaching classes
(D) None of these

ACHIEVERS SECTION

- A delightful movie 'The Gods Must Be Crazy' was made on the tribe of the Kalahari Desert. Which of the following is the name of the tribe?
(A) Santhals
(B) Bedouins
(C) Bushmen
(D) Tuaregs
- _____ is the physicist, engineer and inventor, whose name is synonymous with "small speakers that generate big sound".
(A) Jagadish Chandra Bose
(B) Sumit Ghose
(C) Amar G. Bose
(D) Vinod Dua



SOF INTERNATIONAL
ENGLISH OLYMPIAD

Total Questions : 50

Time : 1 hr.

PATTERN & MARKING SCHEME				
Section	(1) Word and Structure Knowledge	(2) Reading	(3) Spoken and Written Expression	(4) Achievers Section
No. of Questions	30	10	5	5
Marks per Ques.	1	1	1	3



Scan the QR code
for more details

SYLLABUS

Section – 1 : Synonyms, Antonyms, Analogies and Spellings, Collocations, Phrasal Verbs, Idioms or Proverbs, Homonyms and Homophones, One word, Nouns, Pronouns, Verbs, Adverbs, Adjectives, Articles, Prepositions, Prepositional Phrases, Participle Phrases, Conjunctions, Determiners, Jumbled Words and Punctuations, Tenses, Voices and Narrations, Question Tags, etc. Words related to leisure, Household items/issues, Social causes, Outdoor locations and activities, etc.

Section – 2 : Search for and retrieve information from various text types like News reports, Blurb, Dictionaries, etc., Understand information presented in instruction manual format, Message format and others. Acquire broad understanding of and look for specific information in longer texts like Editorials, Essays, etc.

Section – 3 : Ability to understand situation-based variations in functions like Requesting, Giving information, Expressing surprise, Pronunciation, etc.

Section – 4 : Higher Order Thinking Questions - Syllabus as per Sections 1, 2 and 3.

WORD AND STRUCTURE KNOWLEDGE

- Choose the odd pair.
 - Annoy : Irritate
 - Comprehend : Understand
 - Spectator : Onlooker
 - Reserve : Supply

Direction (Q. No. 2 and 3) : Choose the correct option.

- The thief walked away with the diamond crown on display. No one stopped him because he was _____ the director of the museum.
 - contracting
 - impersonating
 - implanting
 - contradicting

- The transmission of the President's speech remained _____ interrupted.
 - mis
 - dis
 - un
 - il

READING

Direction (Q. No. 4 and 5) : Read the following passage and answer the questions that follow.

The greatest threat to life on Earth today comes from global warming. This is caused due to multiple factors including human activity. It happens when greenhouse gases (carbon dioxide, water vapour, nitrous oxide, and methane) trap heat and light from the Sun in the Earth's atmosphere, which increases the overall temperature on Earth. This impacts people, animals, and plants. Many who cannot take the change, die. Global warming is affecting many parts of the world, particularly sea coasts. People living on islands and in coastal areas are therefore at risk as the polar ice caps melt and sea levels rise.

- According to the passage, choose the statement that is false.
 - Life on Earth is threatened only by global warming.
 - Global warming threatens human beings who live on islands.
 - When the overall temperature on Earth rises the sea level will also increase.
 - Creatures which cannot adapt to higher temperatures will become extinct.
- "Many cannot take the change." Here "change" refers to changes in _____.
 - lifestyle
 - food habits
 - temperature
 - health issues

SPOKEN AND WRITTEN EXPRESSION

Direction (Q. No. 6 and 7) : Sentences 1 and 3 are given. Sentence 2 is missing. Choose the right sentence for sentence 2.

- Sona : Hema, I notice your tennis serve is much better these days.
Hema : _____
Sona: Your efforts have not been wasted. There is a remarkable improvement in your game.
 - Yes, I think I've finally mastered the technique, though it took months of practise

- Serving well is an art that can be mastered
- I saw a doctor because I was suffering from tennis elbow
- In tennis, one has to focus on one's serving action

- Mala : I was looking for a birthday present for my nephew but I didn't have much luck. Do you have any bright ideas?
Juhi : _____

Mala : I did think about it, but I felt I should take some trouble and choose something useful.

- (A) Some music, maybe?
- (B) One need not buy a present for everyone.
- (C) You could just give him some money.
- (D) Buying a present is something that only the young enjoy.

Direction (Q.No. 8) : Sentences 1 and 4 are given. Sentences 2 and 3 are missing. Choose two sentences that will complete the paragraph.

8. Sentence 1 : Today's world is full of gizmos and gadgets unimaginable to people thirty years ago.

Sentence 2 : _____.

Sentence 3 : _____.

Sentence 4 : However, keeping abreast of technology seems a difficult job by itself considering the pace at which new gadgets appear on the market.

- (D) The markets cater to this section and keep bringing out products that cater to their taste.
- (E) Students and the youth like to keep abreast of technology.
- (F) Who would have imagined a world of cell phones and ipods?
- (A) D and F (B) E and D
- (C) E and F (D) F and D

ACHIEVERS SECTION

9. Choose the word with the opposite meaning to the underlined word.

The bee is a very industrious creature.

- (A) Hardworking
- (B) Indolent
- (C) Repulsive
- (D) Curious

10. Choose the best option.

If a business person is called munificent, he/she is _____.

- (A) prominent
- (B) miserly
- (C) generous
- (D) rich



SOF NATIONAL SCIENCE OLYMPIAD

Total Questions : 50

Time : 1 hr.

PATTERN & MARKING SCHEME			
Section	(1) Logical Reasoning	(2) Science	(3) Achievers Section
No. of Questions	10	35	5
Marks per Ques.	1	1	3



Scan the QR code for more details

SYLLABUS

Section – 1 : Verbal and Non-Verbal Reasoning.

Section – 2 : Crop Production and Management, Microorganisms, Coal and Petroleum, Combustion and Flame, Conservation of Plants and Animals, Reproduction and Endocrine System, Force and Pressure, Friction, Sound, Chemical Effects of Electric Current, Some Natural Phenomena, Light.

Section – 3 : Higher Order Thinking Questions - Syllabus as per Section – 2.

LOGICAL REASONING

1. Three positions of a dice are shown below. What is the number opposite to 1 ?

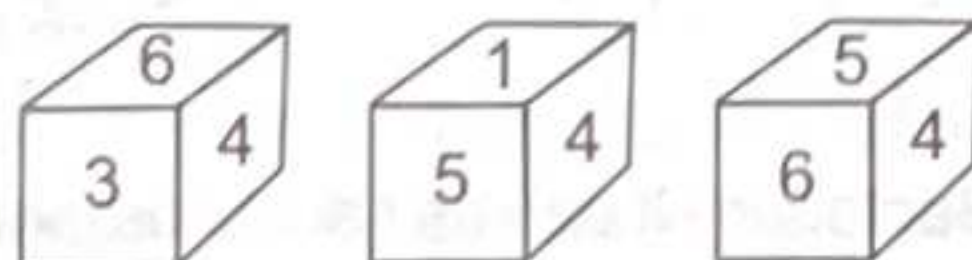

- (A) 2
- (B) 3
- (C) 5
- (D) 6

2. Select the correct water image of the given figure.

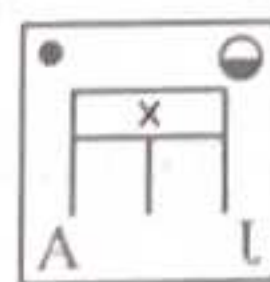

- (A)
- (B)

- (C)
- (D)

3. In the given Venn diagram, find the region representing persons who are educated and employed but not confirmed in job.

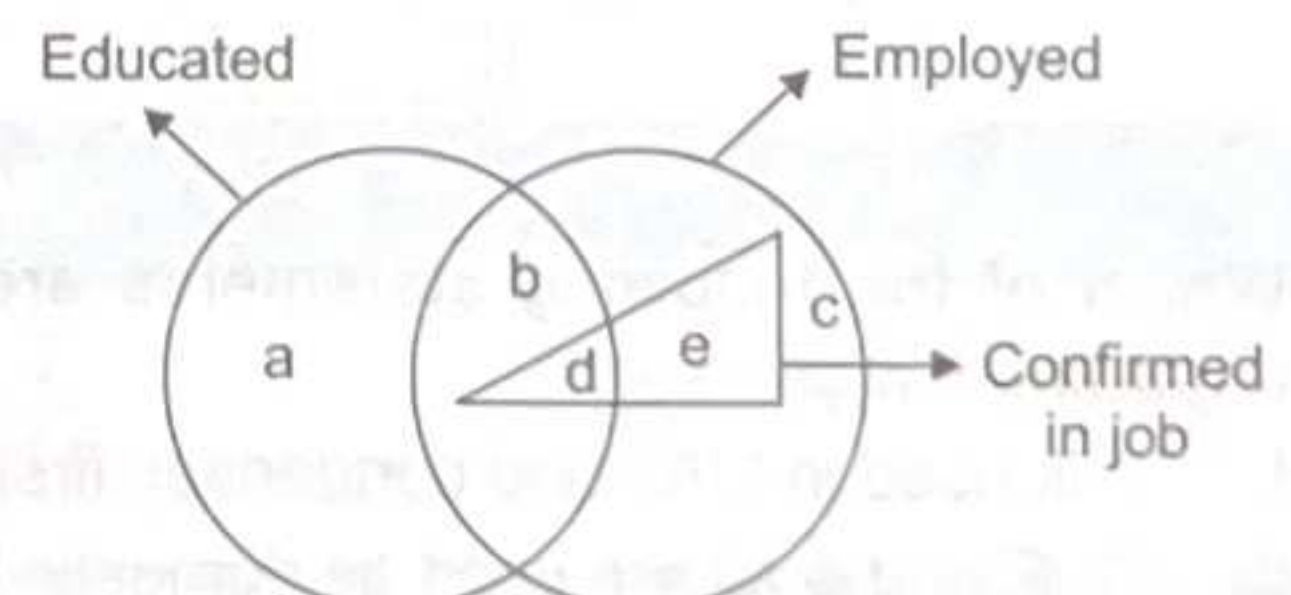

- (A) d
- (B) e
- (C) b
- (D) a, b

4. Bees which are not carrying honey fly with a flapping frequency of 440 Hz while those which are carrying honey fly with a flapping frequency of 300 Hz. The sound made by bees which are not carrying honey has
 (A) A lower pitch
 (B) A higher pitch
 (C) A smaller loudness
 (D) A greater loudness.
5. The pressure of the water near the bottom of the wall forming a dam does not depend on _____.
 (A) The depth of the water
 (B) The cross-sectional area of the reservoir
 (C) Density of water
 (D) Atmospheric pressure
6. Which of the following statements are correct?
 I. Substance which undergoes spontaneous combustion have ignition temperature higher than the room temperature.
 II. Respiration is a special combustion reaction at body temperature.
- III. Formation of rust is an example of slow combustion.
 IV. Combustion is an exothermic reaction.
 (A) I and II only
 (B) II and IV only
 (C) I, II and IV only
 (D) II, III and IV only
7. Which of the following on reshuffling gives the term that refers to the process of sowing seeds manually by sprinkling them on soil by hand?
 (A) INLGTIL
 (B) GLNOPUIHG
 (C) ATNBRDOCAIGS
 (D) GIOWNWINN
8. Which of the following groups represents the bacterial diseases?
 (A) Cholera, Tuberculosis, Malaria, Measles
 (B) Small pox, Tuberculosis, Malaria, Typhoid
 (C) Cholera, Tuberculosis, Typhoid, Measles
 (D) Cholera, Anthrax, Tuberculosis, Typhoid

ACHIEVERS SECTION

9. The given figure represents fractional distillation of petroleum.

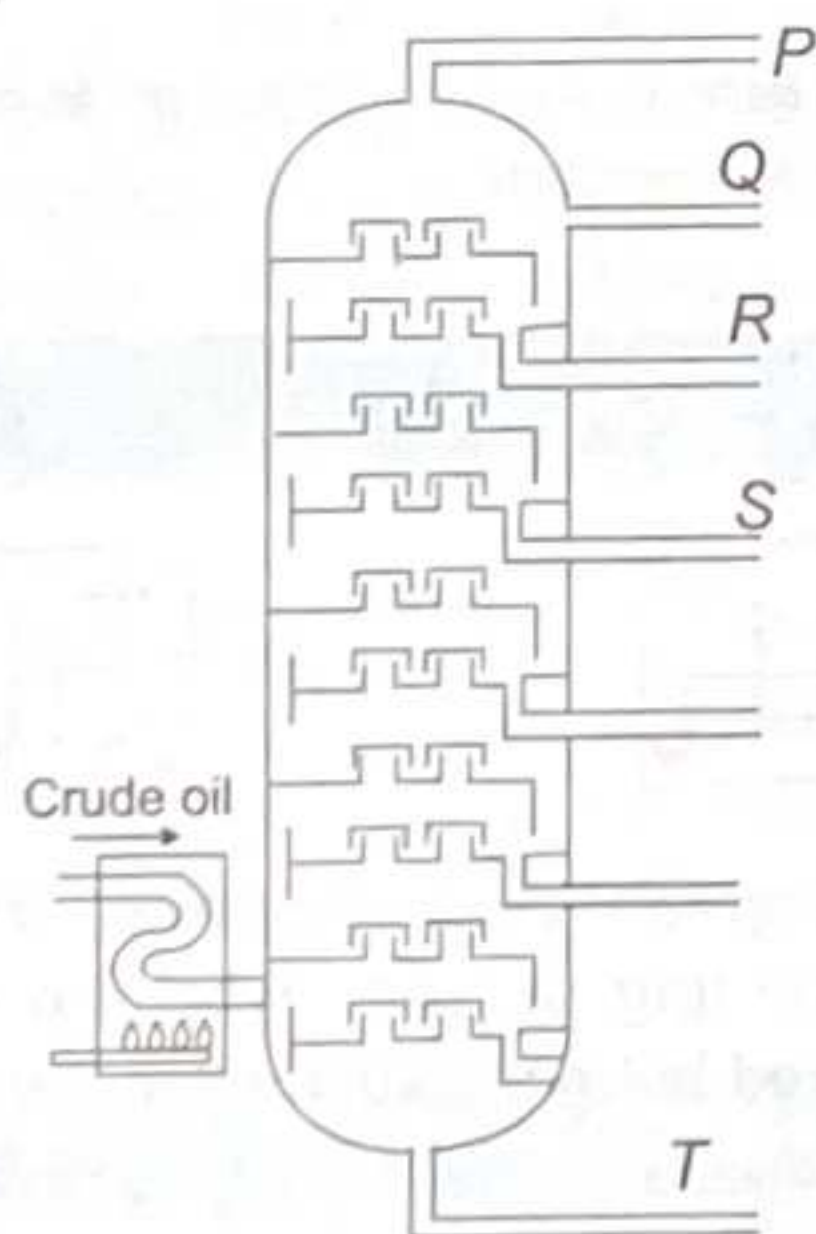

Which of the following statements are correct regarding this process?

- I. P is used in LPG and condenses first.
 II. Q, R and S all are used as domestic fuels.
 III. The increasing order of boiling points is $P < Q < R < S < T$
 IV. Paraffin wax is obtained from T.
 (A) III and IV only

- (B) I and III only
 (C) II, III and IV only
 (D) I, III and IV only

10. Refer to the given figures of bacteria X, Y and Z and read the statements (i), (ii), (iii) and (iv) regarding them.

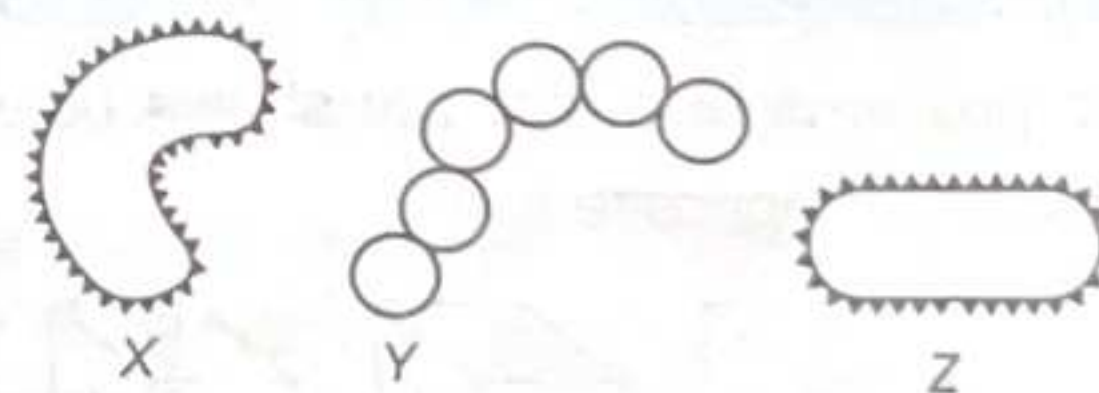

- (i) Bacterium X can be causal organism of typhoid.
 (ii) Bacterium Y can cause a disease which disrupts proper exchange of gases.
 (iii) Bacterium Z can convert lactose sugar of milk into lactic acid.
 (iv) Bacterium X can be the causal organism of cholera.

Which of these statements are incorrect?

- (A) (i) only
 (B) (i) and (ii) only
 (C) (ii), (iii) and (iv) only
 (D) (i), (ii), (iii) and (iv)

PATTERN & MARKING SCHEME				
Section	(1) Logical Reasoning	(2) Mathematical Reasoning	(3) Everyday Mathematics	(4) Achievers Section
No. of Questions	15	20	10	5
Marks per Ques.	1	1	1	3



Scan the QR code for more details

SYLLABUS

Section – 1 : Verbal and Non-Verbal Reasoning.

Section – 2 : Rational Numbers, Squares and Square Roots, Cubes and Cube Roots, Exponents and Powers, Comparing Quantities, Algebraic Expressions, Linear Equations in One Variable, Understanding Quadrilaterals, Mensuration, Data Handling, Direct and Inverse Proportions, Factorisation, Introduction to Graphs.

Section – 3 : Syllabus as per Section – 2.

Section – 4 : Higher Order Thinking Questions - Syllabus as per Section – 2.

LOGICAL REASONING

1. Pointing to a man in a photograph, a woman says, "He is the only son of the only daughter-in-law of my only son's father." How is the man related to the woman?

- (A) Son
- (B) Father
- (C) Son-in-law
- (D) Grandson

- (A) 6
- (B) 2
- (C) 3
- (D) 5

2. Three different positions of a dice are given below:

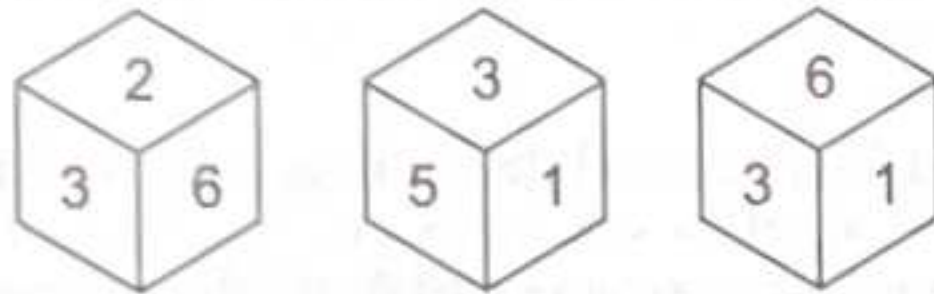

Which number is on the face opposite to 1?

3. The digits of each of the following five numbers are written in reverse order and five new numbers are obtained :

513 726 492 865 149

Which of the following will be the third digit of the second highest new number?

- (A) 1
- (B) 5
- (C) 7
- (D) 8

MATHEMATICAL REASONING

4. The area of a rectangle is given by $6x^2y + 4y^2x$ and the width of the rectangle is given by $2xy$. Find the perimeter of rectangle.

- (A) $6x + 8y + 2xy$
- (B) $3x + 4y + 2xy$
- (C) $8x + 6y + 4xy$
- (D) $6x + 4y + 4xy$

- (A) $\frac{2}{5}$
- (B) $\frac{3}{4}$
- (C) $\frac{3}{5}$
- (D) $\frac{3}{10}$

5. In a class of 100 students, 30% of the students offered English, 20% offered Hindi. If a student is selected at random, then what is the probability that he has offered English?

6. If $3^{x+y} = 81$ and $81^{x-y} = 3^8$, then find the values of x and y respectively.

- (A) 3, 1
- (B) 1, 3
- (C) -1, 3
- (D) -1, -3

EVERYDAY MATHEMATICS

7. Sanket earns twice as much in the month of March as in each of the other months of the year. What part of his entire annual earnings was earned in March?

- (A) $\frac{1}{7}$
- (B) $\frac{1}{6}$

- (C) $\frac{2}{11}$
- (D) $\frac{2}{13}$

8. The perimeter of a triangular field is $6p^2 - 4p + 9$ and two of its sides are $p^2 - 2p + 1$ and $3p^2 - 5p + 3$. Find the third side of the field.

- (A) $8p^2 + 11p - 7$
- (B) $2p^2 + 3p + 5$
- (C) $3p^2 + 5p - 4$
- (D) $5p^2 - 5p + 9$

ACHIEVERS SECTION

9. Fill in the blanks and select the correct option.
- (i) A number ending in (P) number of zeroes is never a perfect square.
 - (ii) The square of an (Q) natural number can always be written as the sum of two consecutive positive integers.
 - (iii) The sum of the first n odd natural numbers is (R).
 - (iv) If $(3 \times 3 \times 7)^2 = 3969$, then $\sqrt{3969} = \underline{\text{(S)}}$.
- | | (P) | (Q) | (R) | (S) |
|-----|------|------|-------|-----|
| (A) | Odd | even | $2n$ | 62 |
| (B) | Even | odd | n^2 | 69 |
| (C) | Even | even | n^3 | 39 |
| (D) | Odd | odd | n^2 | 63 |
10. Fill in the blanks and select the correct option.
- (i) The cost of digging a cuboidal pit which is 8 m long, 6 m broad and 3 m deep at the rate of ₹ 30 per m^3 is ₹ P.
 - (ii) A petrol tank is in the form of a cylinder diameter of which is 3 m and length is 7 m. The quantity of petrol that can be stored in it is Q litres. ($1000 \text{ cm}^3 = 1 \text{ litre}$)
- | | P | Q |
|-----|------|-------|
| (A) | 4320 | 35800 |
| (B) | 4080 | 49000 |
| (C) | 4320 | 49500 |
| (D) | 3150 | 30500 |



**SOF INTERNATIONAL
COMPUTER SCIENCE OLYMPIAD**

Total Questions : 50

Time : 1 hr.

PATTERN & MARKING SCHEME				
Section	(1) Logical Reasoning	(2) Computer Science	(3) Information Technology	(4) Achievers Section
No. of Questions	10	30	5	5
Marks per Ques.	1	1	1	3



Scan the QR code for more details

SYLLABUS

Section - 1 : Verbal and Non-Verbal Reasoning.

Section - 2 : Fundamentals of Computers, Algorithms & Flowcharts (Advanced symbols), HTML & CSS [Html, Head, Title, Body (Attributes: Background, Bgcolor, Text, Link, Alink, Vlink), Font (Attributes: Color, Size, Face), Center, BR, HR (Attributes: Size, Width, Align, Noshade, Color), Comment tag(<!-- -->), <H1>..<H6>, <P>, , <I>, <U>, , Html Elements: A, Ul and Ol (Attributes: Type, Start, Li), Flash CS6, MS-Access, Networking, MS-Word (Exploring File tab, Language and Translate options, Tracking features -Comments, Reviewing Pane, Tracking Changes, Comparing, Combining and Protecting documents, Working with References), MS-PowerPoint (Exploring File tab and Slide Show tab, Comparing, Combining and Protecting presentations), MS-Excel(Exploring File tab, Useful Formulas and Functions - IF,Even, Odd, LCM, GCD, Power, Product, Round, Sqrt, Sum, Min, Max, Average, Count, Upper, Lower And Replace, Cell referencing, Using Defined Names group), Memory & Storage Devices, Number System (Introduction), Cyber Safety, Operating Systems(Introduction, Features, Types-single user and multi-user).

Section - 3 : AI, Robotics, IT Gadgets, Devices, Apps, Computerization, and other Developments in the Field of IT.

Section - 4 : Higher Order Thinking Questions - Syllabus as per Sections 2 and 3.

Questions are based on Windows 10 and MS-Office 2016.

LOGICAL REASONING

1. Select the correct mirror image of the given word, if the mirror is placed vertically to the right.

L e O P A r D

- (A) D r A P O e L
- (B) D r A P O e L
- (C) D r A P O e L
- (D) D r A P O e L

2. Select a figure from the options, which satisfies the same conditions of the placement of the dots as in Fig. (X).

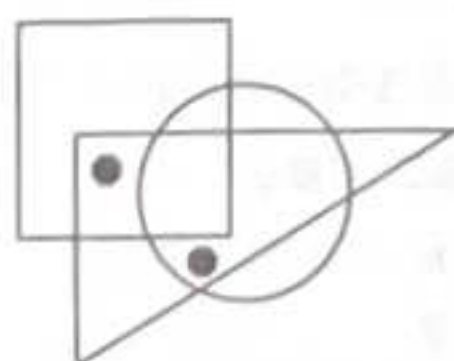
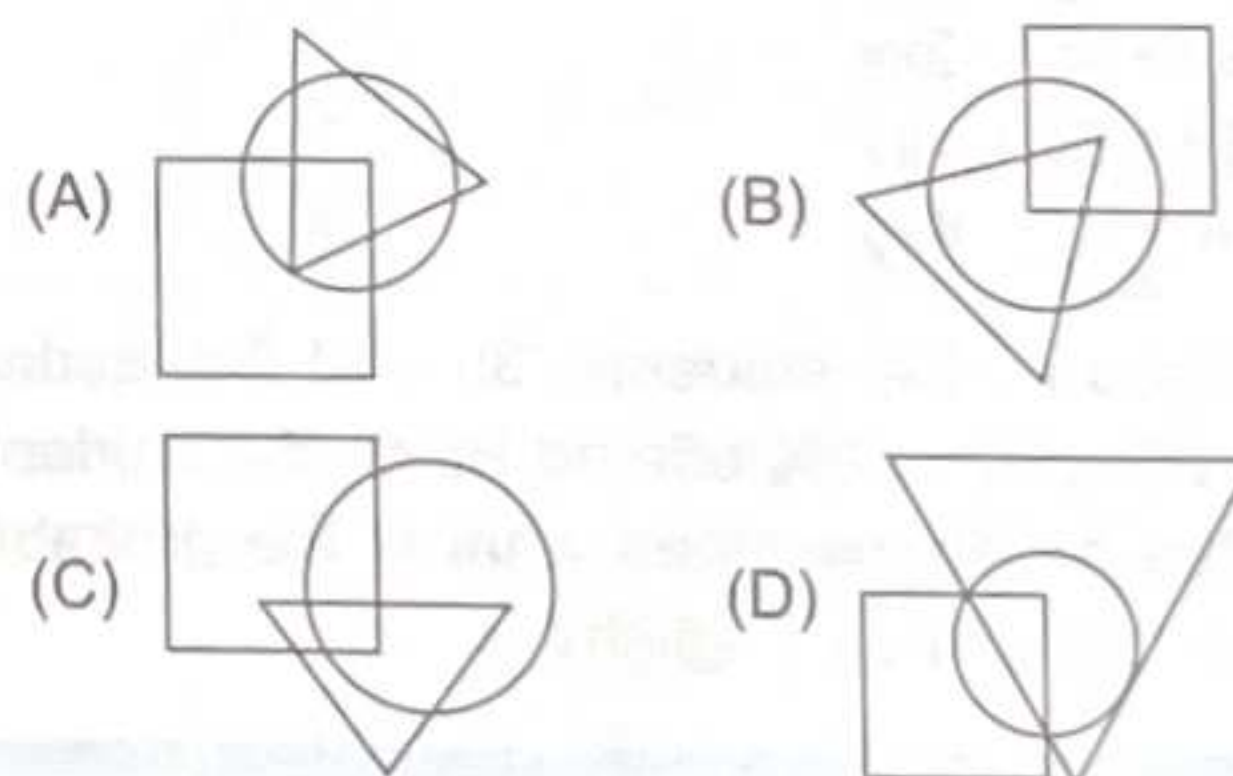

Fig. (X)



3. How many 7s are there in the following series which are preceded by even number and followed by odd number?
- 8 7 6 7 8 6 7 5 6 7 9 7 6 1 6 7 7 6 8 8 6 9 7 6 8 7
- (A) None
 - (B) One
 - (C) Two
 - (D) Three

COMPUTER SCIENCE

4. Which of the following is not available as a category in Control Panel of Windows 10?
- (A) System and Security
(B) Network and Internet
(C) Bluetooth Settings
(D) Ease of Access
5. The function of given icon in MS-Word 2016 is _____.
- (A) To mark the document as final
- (B) To insert an index into the document
(C) Merge document to PDF files
(D) Insert Flash video
6. CSS is used to style an HTML document. Here, CSS stands for _____.
- (A) Computer Style Sheets
(B) Combined Sheet Styles
(C) Common Sheet Styles
(D) Cascading Style Sheets



INFORMATION TECHNOLOGY

7. _____ refers to the simulation of human intelligence in machines that are programmed to think and act like humans.
- (A) Artificial intelligence
(B) Biometric
(C) Bio-technology
(D) All of these
8. Which of the following operating systems is used in air traffic control systems, robots and missile systems?
- (A) Real Time OS
(B) Multitasking OS
(C) Batch OS
(D) Distributed OS

ACHIEVERS SECTION

9. Which of the following statements hold(s) true about telnet?
- Statement 1 : It allows to connect to remote computers.
Statement 2 : It only allows to buy and sell online products.
- (A) Only Statement 1
(B) Only Statement 2
(C) Both Statement 1 and Statement 2
(D) Neither Statement 1 nor Statement 2
10. Select the incorrect statement(s) about single user operating system.
- (A) It is useful for a computer intended to run multiple users at once.
(B) It is used by only one user at a time.
(C) Both (A) and (B)
(D) None of these



SOF INTERNATIONAL
SOCIAL STUDIES OLYMPIAD

Total Questions : 50

Time : 1 hr.

PATTERN & MARKING SCHEME

Section	(1) History	(2) Geography	(3) Social and Political Life	(4) Achievers Section
No. of Questions	20	15	10	5
Marks per Ques.	1	1	1	3



Scan the QR code
for more details

SYLLABUS

Section – 1 : History – Modern India-Sources and Significance, The Establishment of Company Power, Rural Life and Tribal Societies, The Revolt of 1857-58, Education and British Rule, Women, Caste and Reforms, Freedom Struggle in India

Section – 2 : Geography – Resources (Natural, Man-made and Human Resources), Land, Soil, Water, Natural Vegetation and Wildlife Resources, Agriculture and Industries

Section – 3 : Social and Political Life – The Indian Constitution and Secularism, Parliamentary Government and the Judiciary, Social Justice and the Marginalised, Economic Presence of the Government

Section – 4 : Higher Order Thinking Questions - Syllabus as per Section – 1, 2 & 3.

1. The Silent Valley National Park in Kerala is home to a large population of which endangered primate?
- (A) Chimpanzee
(B) Orangutan
(C) Gorilla
(D) Lion-tailed macaque
2. Which of the following states in India is not prone to tropical cyclones?
- (A) Bihar
(B) Odisha

- (C) West Bengal (D) Tamil Nadu
3. Who introduced Doctrine of Lapse?
 (A) Lord Wellesley (B) Robert Clive
 (C) Lord Dalhousie (D) Lord Mountbatten
4. Which tribal group inhabited the Chota Nagpur Plateau region?
 (A) Kol (B) Onge
 (C) Bhil (D) Munda
5. Rabindranath Tagore established the
 (A) Maharaja Sayajirao University
 (B) Aligarh Muslim University
 (C) Visva Bharati University
 (D) Kolkata University.
6. Which of the following is not an eligibility criteria to become a member of the Lok Sabha?
 (A) The candidate must be a citizen of India.

- (B) The age should not be less than 25 years.
 (C) He should have the citizenship of another country.
 (D) All of these

7. If there is a dispute between centre and state for resources allocation, which of the following has the authority to hear such case?
 (A) High Court
 (B) District and Sessions Court
 (C) Supreme Court
 (D) Both (A) and (B)
8. Which committee was set-up by the government to examine status of Muslim community in India?
 (A) Santhanam
 (B) Justice Verma
 (C) Sachar
 (D) Kelkar

ACHIEVERS SECTION

9. Which of the following statement(s) is/are correct?
 (i) The British and the Marathas fought three wars.
 (ii) The British annexed Awadh in 1849.
 (iii) In 1905, Viceroy Curzon partitioned Bengal, which included Bihar and parts of Orissa.
 (A) (i) and (iii) only
 (B) (ii) only
 (C) (ii) and (iii) only
 (D) (i), (ii) and (iii)
10. Select the option that correctly identifies our fundamental rights.
 (i) Right against exploitation
 (ii) Right to freedom of religion
 (iii) Right to equality
 (iv) Right to freedom
 (v) Right to constitutional remedies
 (A) (ii), (iii) and (iv) only
 (B) (i), (ii), (iii), (iv) and (v)
 (C) (i) and (v) only
 (D) (i), (iii) and (iv) only



SOF INTERNATIONAL HINDI
OLYMPIAD

कुल प्रश्न : 50

कुल समय : 1 घंटा

पैटर्न तथा अंक योजना			
खंड	(1) शब्द और व्याकरण बोध	(2) रचनात्मक बोध	(3) मेधावी खंड
प्रश्नों की संख्या	35	10	5
अंक प्रति प्रश्न	1	1	3



Scan the QR code
for more details

पाठ्यक्रम

खंड-1: भाषा-विचार, वर्ण-विचार, शब्द-विचार, संधि एवं समास, शब्द-भंडार, उपसर्ग एवं प्रत्यय, संज्ञा, सर्वनाम एवं विशेषण, काल, क्रिया एवं कारक, लिंग एवं वचन, अविकारी शब्द, वाक्य परिवर्तन, अशुद्धि संशोधन और विराम-चिह्न, अलंकार, गिनती, महीनों के नाम, भारतीय साहित्य एवं संस्कृति।

खंड-2: अपठित गद्यांश, अपठित पद्यांश, मुहावरे एवं लोकोक्तियाँ।

खंड-3: उच्चतर क्रम सोच कौशल आधारित प्रश्न- खंड 1 और 2 के पाठ्यक्रम के अनुसार

शब्द और व्याकरण बोध

1. 'हमारे देश में विभीषणों की कमी नहीं है।' वाक्य में रेखांकित शब्द, संज्ञा का कौन-सा भेद है?
 (क) भाववाचक
 (ख) जातिवाचक
 (ग) व्यक्तिवाचक
 (घ) द्रव्यवाचक
2. _____ शब्द व्युत्पत्ति के आधार पर यौगिक है।
 (क) कमल
 (ख) रसोईघर
 (ग) घर
 (घ) (क) और (ग) दोनों

3. ज्ञान हमें तिमिर से ————— की ओर ले जाता है।
(उचित विलोम शब्द द्वारा रिक्त स्थान भरिए।)
(क) प्रकाश
(ख) अंबर
(ग) सूर्य
(घ) अतिमिर
4. निम्नलिखित में से 'संस्कार' शब्द में प्रयुक्त उपसर्ग चुनिए—
(क) सं
(ख) संस्
(ग) सन्
(घ) सम्
5. 'जो पौधों में पानी डाल रहा है, वह मेरा भाई है।' इस वाक्य में कौन-सा सर्वनाम प्रयुक्त है?
(क) निजवाचक सर्वनाम
(ख) पुरुषवाचक सर्वनाम
(ग) संबंधवाचक सर्वनाम
(घ) निश्चयवाचक सर्वनाम
6. निम्नलिखित में से किस वाक्य में अनुप्रास अलंकार नहीं है?
(क) रहिमान पानी राखिये, बिन पानी सब सून।
(ख) सेवक सचिव सुमंत बुलाए।
(ग) गिरी का गौरव गाकर, झर-झर।
(घ) कूलन में केलिन में, कछारन में कुंजन में।

रचनात्मक बोध

निम्नलिखित गद्यांश को पढ़कर प्रश्न संख्या 7 और 8 के उत्तर दीजिए—

प्रचारित किया जाता रहा है कि कश्मीर भू-स्वर्ग है। उसका प्राकृतिक सौंदर्य अपूर्व है। इस प्रचार के पीछे कोई विशेष उद्देश्य होगा। ऐसे प्रचारकों ने किसी निहित उद्देश्य के कारण मनाली की मनोरम प्राकृतिक सुषमा को अनदेखा कर दिया। कुल्लू के निवासी अत्यंत कठोर जीवन के अभ्यस्त हैं। हँसते-मुसकराते उन्हें खेतों एवं बगीचों में कठिन परिश्रम करते देख सकते हैं। सेब के उत्पादन में विशिष्टता के साथ-साथ अब यहाँ अखरोट, बादाम, नाशपाती तथा विभिन्न प्रकार की जीवनदायिनी जड़ी-बूटियों का भी उत्पादन होने लगा है।

मनाली महर्षि मनु की पावन भूमि है। मनाली अर्थात् 'मनु आलय'। 'मनुस्मृति' महर्षि मनु द्वारा रचित हिंदू धर्मशास्त्र का एक प्रमुख ग्रंथ है। इस ग्रंथ में बारह अध्याय हैं।

मनाली को ही कुल्लू का मुख्य पर्यटक स्थल माना जाता है। प्रकृति की मनोरम कृश्यावली हृदय को अभिभूत कर देती है। ब्यास को हिमाचल की नदियों में श्रेष्ठतम माना जाता है। वैदिक काल में इसका नाम विपाशा था। शाब्दिक अर्थ के अनुसार, विपाशा का मतलब है—

'बंधन-रहित' या 'बंधन-मुक्त' अर्थात् वह नदी जो अपना किनारा स्वयं बनाती है। पथ में आई प्रत्येक रुकावट, शिलाखंड, हर प्रकार की बाधा को दूर करती हुई मुक्त रूप से उमगती किलकती प्रवाहित हो, यह है विपाशा।

7. किसकी प्राकृतिक सुषमा को अनदेखा कर दिया गया?
(क) शिमला
(ख) कश्मीर
(ग) हिमालय
(घ) मनाली

8. मनुस्मृति ————— की रचना है।
(क) महर्षि वाल्मीकि
(ख) विष्णु शर्मा
(ग) महर्षि मनु
(घ) कालिदास

मेधावी खंड

9. अविकारी शब्दों के भेदों के आधार पर उचित मिलान के विकल्प का चयन कीजिए—

अविकारी शब्द	उदाहरण
(अ) संबंधबोधक	(i) गरीबों को दुत्कारना नहीं चाहिए बल्कि उनकी मदद करनी चाहिए।
(ब) समुच्चयबोधक	(ii) गरमी के मारे सभी का बुरा हाल है।
(स) क्रियाविशेषण	(iii) तुम अंदर चलो।
(द) निपात	(iv) मैं भी दिल्ली जाऊँगा।
(क) अ-(iii), (ख) अ-(ii), (ग) अ-(ii), (घ) अ-(i),	ब-(iv), स-(i), द-(ii) ब-(i), स-(iii), द-(iv) ब-(i), स-(iv), द-(iii) ब-(iii), स-(ii), द-(iv)

10. दी गई तालिका का ध्यानपूर्वक अध्ययन कर उचित विकल्प का चयन कीजिए—

शब्द	उपसर्ग
(अ) नादान	ना
(ब) अभिनय	अभि
(स) अनाथ	अ
(द) अनमोल	अन
(क) (अ) और (द) दोनों सही हैं।	
(ख) (अ) और (ब) दोनों सही हैं।	
(ग) केवल (अ) सही है।	
(घ) उपरोक्त सभी सही हैं।	

